

**MODUL 3**  
**MATEMATIK SPM "ENRICHMENT"**  
**TOPIC: CIRCLE, AREA AND PERIMETER**  
**TIME: 2 HOURS**

1. Diagram 1 shows two sector of circle  $ORQ$  and  $OPS$  with centre  $O$ .

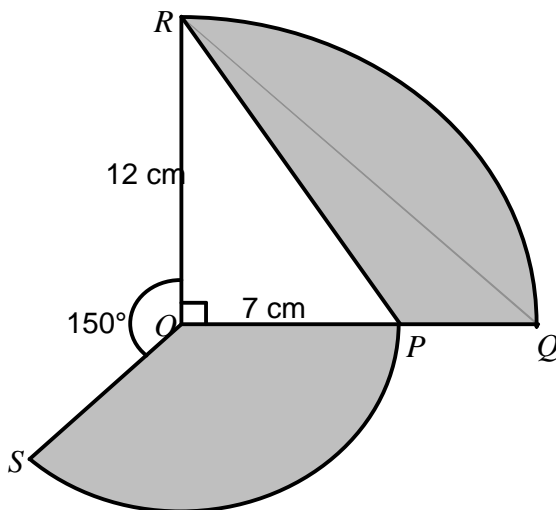

DIAGRAM 1

By using  $\pi = \frac{22}{7}$ , calculate

- (a) the perimeter for the whole diagram in cm,  
(b) area of the shaded region in  $\text{cm}^2$ .

[ 6 marks ]

Answer :

(a)

(b)

2. In diagram 2,  $ABCD$  is a rectangle.

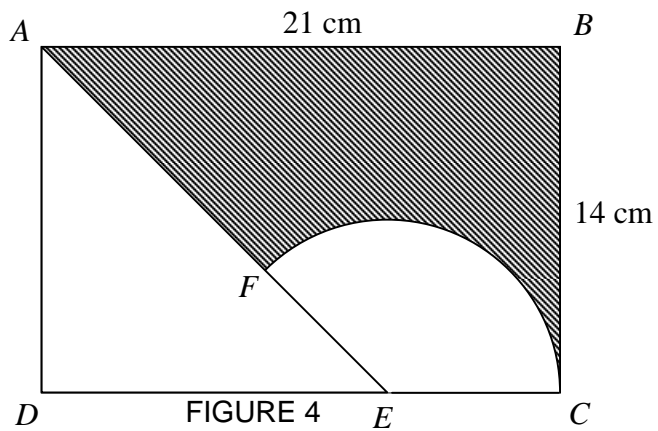

$CF$  is an arc of a circle with center  $E$  where  $E$  is a point on the line  $DC$  with  $EC = 7\text{ cm}$ . Using  $\pi = \frac{22}{7}$ , calculate

- the length, in  $\text{cm}$ , of arc  $CF$
- the area, in  $\text{cm}^2$ , of the shaded region

[ 6 marks ]

Answer :

(a)

(b)

3. Diagram 3 shows two sectors  $OPQR$  and  $OJKL$ .  
 $OPQR$  and  $OJKL$  are three quarters of a circle.  
 $POL$  and  $JOR$  are straight lines.  $OP = 21\text{cm}$  and  $OJ = 7\text{ cm}$ .

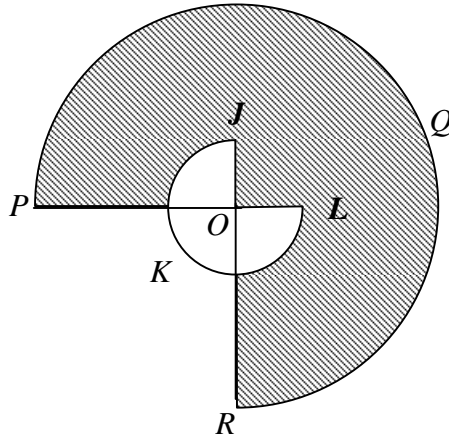

DIAGRAM 3

Using  $\pi = \frac{22}{7}$ , calculate

- (a) the perimeter, in cm, of the whole diagram,  
(b) the area, in  $\text{cm}^2$ , of the shaded region.

[6 marks]

Answer:

(a)

(b)

4. In Diagram 4,  $JK$  and  $PQ$  are arcs of two circles with centre  $O$ .  $OQRT$  is a square.

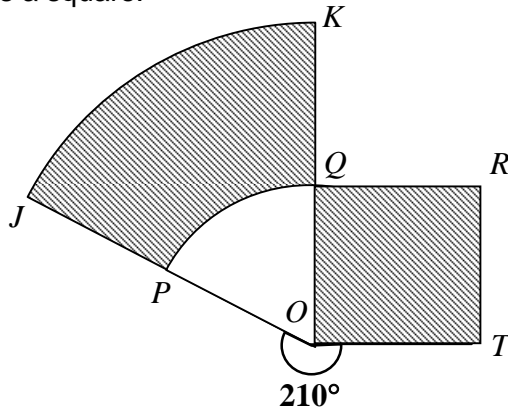

DIAGRAM 4

$OT = 14$  cm and  $P$  is the midpoint of  $OJ$ .

Using  $\pi = \frac{22}{7}$ , calculate

- (a) the perimeter, in cm, of the whole diagram,
- (b) the area, in  $\text{cm}^2$ , of the shaded region.

[6 marks]

Answer:

(a)

(b)

5. Diagram 5 shows two sectors OLMN and OPQR with the same centre O.

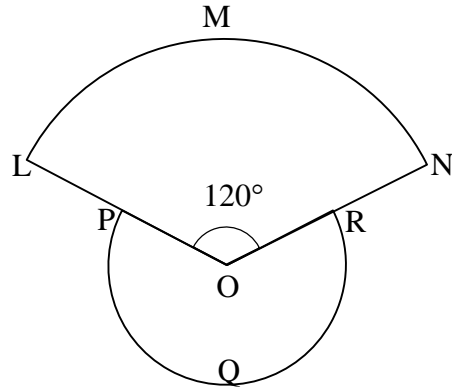

DIAGRAM 5

OL = 14 cm. P is the midpoint of OL.

[Use  $\pi = \frac{22}{7}$ ]

Calculate

- (a) the area of the whole diagram,
- (b) the perimeter of the whole diagram.

[6 marks]

Answer:

(a)

(b)

6. In Diagram 6,  $ABD$  is an arc of a sector with the centre  $O$  and  $BCD$  is a quadrant.

$OD = OB = 14$  cm and  $\angle AOB = 45^\circ$ .

Using  $\pi = \frac{22}{7}$ , calculate

- (a) the perimeter, in cm, of the whole diagram,  
(b) the area, in  $\text{cm}^2$ , of the shaded region.

[6 marks]

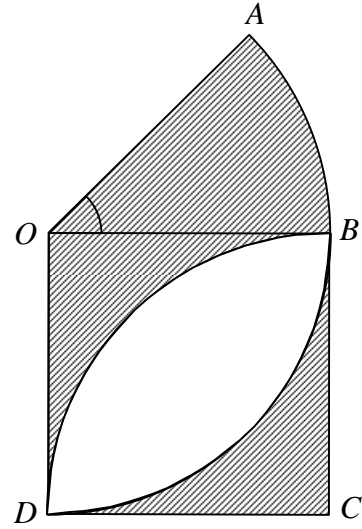

DIAGRAM 6

Answer :

(a)

(b)

7. In Diagram 7, the shaded region represents the part of the flat windscreen of a van which is being wiped by the windscreen wiper  $AB$ . The wiper rotates through an angle of  $210^\circ$  about the centre  $O$ . Given that  $OA = 7$  cm and  $AB = 28$  cm.

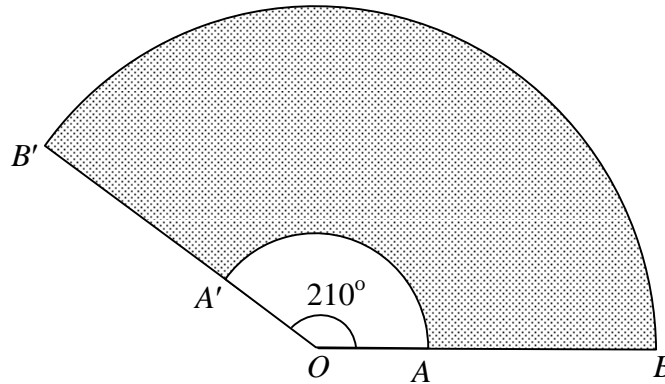

DIAGRAM 7

Using  $\pi = \frac{22}{7}$ , calculate

- the length of arc  $BB'$ ,
- the ratio of arc lengths,  $AA' : BB'$
- the area of the shaded region.

[7 marks]

*Answer.*

(a)

(b)

(c)

8. Diagram 8 shows a quadrant  $ADO$  with centre  $O$  and a sector  $BEF$  with centre  $B$ .  $OBC$  is a right angled triangle and  $D$  is the midpoint of the straight line  $OC$ . Given  $OC = OB = BE = 14$  cm.

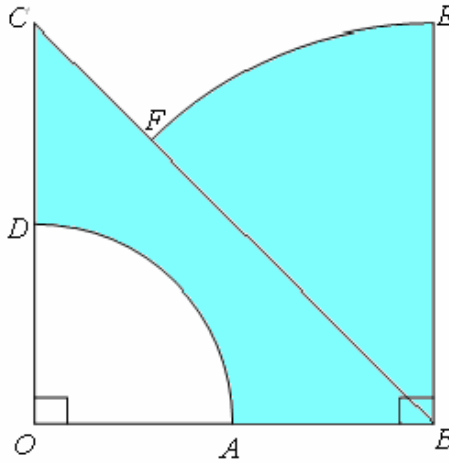

DIAGRAM 8

Using  $\pi = \frac{22}{7}$ , calculate

- (a) the perimeter, in cm, of the whole diagram,  
(b) the area, in  $\text{cm}^2$ , of the shaded region.

[6 marks]

Answer:

(a)

(b)

9. In Diagram 9,  $OPQS$  is a quadrant with the centre  $O$  and  $OSQR$  is a semicircle with the centre  $S$ .

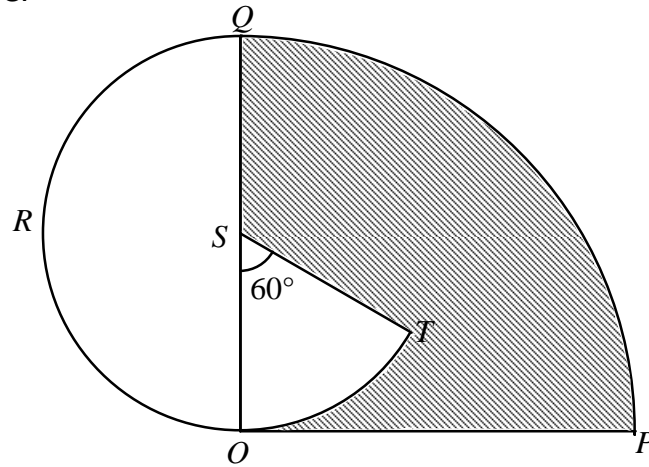

DIAGRAM 9

Given that  $OP = 14$  cm. Using  $\pi = \frac{22}{7}$ , calculate

- (a) the area, in  $\text{cm}^2$ , of the shaded region,  
(b) the perimeter, in cm, of the whole diagram.

[6 marks]

*Answer.*

(a)

(b)

10. In diagram 10,  $OABC$  is a sector of a circle with centre  $O$  and radius 14 cm.

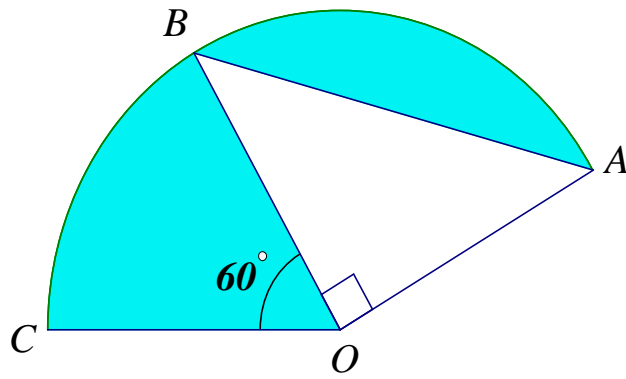

DIAGRAM 10

By using  $\pi = \frac{22}{7}$ , calculate

- (a) perimeter, in cm, the shaded area.
- (b) area, in  $\text{cm}^2$ , the shaded area.

[7 markah]

Answer :

(a)

(b)

**MODULE 3 - ANSWERS**  
**TOPIC: CIRCLE, AREA AND PERIMETER**

**1**

(a)  $\frac{90}{360} \times 2 \times \frac{22}{7} \times 12 @ \frac{120}{360} \times 2 \times \frac{22}{7} \times 7$  K1

$\frac{90}{360} \times 2 \times \frac{22}{7} \times 12 + \frac{120}{360} \times 2 \times \frac{22}{7} \times 7 + 12 + 5$  K1

57.53

N1

(b)  $\frac{90}{360} \times \frac{22}{7} \times 12^2 @ \frac{120}{360} \times \frac{22}{7} \times 7^2$  K1

$\frac{90}{360} \times \frac{22}{7} \times 12^2 + \frac{120}{360} \times \frac{22}{7} \times 7^2 - \frac{1}{2} \times 7 \times 12$  K1

122.48

N1

**2**

(a)  $\angle FEC = 135^\circ$  K2

$\frac{135}{360} \times 2 \times \frac{22}{7} \times 7$  K1

16.5

N1

(b)  $L_3 = \frac{135}{360} \times \frac{22}{7} \times 7 \times 7$  K1

$Shaded\ area = (21 \times 14) - \left( \frac{1}{2} \times 14 \times 14 \right) - L_3$  K1

= 138.25

N1

**3**

a)  $\frac{270}{360} \times \frac{22}{7} \times 2 \times 21$  atau  $\frac{90}{360} \times \frac{22}{7} \times 7 \times 2$  K1

$\frac{270}{360} \times \frac{22}{7} \times 2 \times 21 + \frac{90}{360} \times \frac{22}{7} \times 7 \times 2 + 14 + 14$  K1

= 138

N1

b)  $\frac{270}{360} \times \frac{22}{7} \times 21 \times 21$  atau  $2 \times \frac{90}{360} \times \frac{22}{7} \times 7 \times 7$  K1

$\frac{270}{360} \times \frac{22}{7} \times 21 \times 21 - 2 \times \frac{90}{360} \times \frac{22}{7} \times 7 \times 7$  K1

= 962.5 cm<sup>2</sup> N1

**4**

a)  $\frac{60}{360} \times 2 \times \frac{22}{7} \times 28$  K1

$\frac{60}{360} \times 2 \times \frac{22}{7} \times 28 + 14 + 14 + 14 + 14 + 28$  K1

$113\frac{1}{3}$  atau 113.33 N1

b)  $\frac{60}{360} \times \frac{22}{7} \times 28 \times 28$  atau  $\frac{60}{360} \times \frac{22}{7} \times 14 \times 14$  K1

$\frac{60}{360} \times \frac{22}{7} \times 28 \times 28 - \frac{60}{360} \times \frac{22}{7} \times 14 \times 14 + 14 \times 14$  K1

504 N1

**5**

a)  $\frac{120}{360} \times \frac{22}{7} \times 14 \times 14$  atau  $\frac{240}{360} \times \frac{22}{7} \times 7 \times 7$  K1

$\frac{120}{360} \times \frac{22}{7} \times 14 \times 14 + \frac{240}{360} \times \frac{22}{7} \times 7 \times 7$  K1

308 N1

b)  $\frac{120}{360} \times 2 \times \frac{22}{7} \times 14$  atau  $\frac{240}{360} \times 2 \times \frac{22}{7} \times 7$  K1

$\frac{120}{360} \times 2 \times \frac{22}{7} \times 14 + \frac{240}{360} \times 2 \times \frac{22}{7} \times 7 + 7 + 7$  K1

$72\frac{2}{3}$  N1

**6**

(a)  $\frac{45}{360} \times 2 \times \frac{22}{7} \times 14$  K1

$\left( \frac{45}{360} \times 2 \times \frac{22}{7} \times 14 \right) + 14 + 14 + 14 + 14$  K1

$70\frac{2}{3}$  N1

(b)  $\frac{45}{360} \times \frac{22}{7} \times 14 \times 14$  or  $\frac{90}{360} \times \frac{22}{7} \times 14 \times 14$  K1

$\left( \frac{45}{360} \times \frac{22}{7} \times 14 \times 14 \right) + 2 \left( 14 \times 14 - \frac{90}{360} \times \frac{22}{7} \times 14 \times 14 \right)$  K1

161 N1

**7**

(i)  $\frac{210}{360} \times 2 \times \frac{22}{7} \times 35$  K1

$128\frac{1}{3}$  @ 128.33 N1

(ii)  $\frac{210}{360} \times 2 \times \frac{22}{7} \times 7 : \frac{210}{360} \times 2 \times \frac{22}{7} \times 35$  K1

1: 5 N1

(iii)  $\frac{210}{360} \times \frac{22}{7} \times 35^2$  or  $\frac{210}{360} \times \frac{22}{7} \times 7^2$  K1

$\frac{210}{360} \times \frac{22}{7} \times 35^2 - \frac{210}{360} \times \frac{22}{7} \times 7^2$  K1

2156 N1

**8**

(a)  $\frac{45}{360} \times 2 \times \frac{22}{7} \times 14$  or  $\sqrt{14^2 + 14^2} - 14$  K1

11 + 14 + 14 + 14 + 5.799 K1

58.80 (2 d. p) N1

(b)  $\frac{90}{360} \times \frac{22}{7} \times 7 \times 7$  or  $\frac{45}{360} \times \frac{22}{7} \times 14 \times 14$  K1

$\frac{1}{2} \times 14 \times 14 - \frac{90}{360} \times \frac{22}{7} \times 7 \times 7 + \frac{45}{360} \times \frac{22}{7} \times 14 \times 14$  K1

136.5 N1

**9**

(a)  $A_1 = \frac{90}{360} \times \frac{22}{7} \times 14 \times 14$  and  $A_2 = \frac{60}{360} \times \frac{22}{7} \times 7 \times 7$  K1

$A_1 - A_2$  K1

$128\frac{1}{3}$  N1

(b)  $P_1 = \frac{90}{360} \times 2 \times \frac{22}{7} \times 14$  or  $P_2 = \frac{180}{360} \times 2 \times \frac{22}{7} \times 7$  K1

$P_1 + P_2 + 14$  K1

- 10 58 N1
- (a)  $AB = \sqrt{14^2 + 14^2} = \sqrt{392} = 19.80$  K1
- $\frac{150}{360} \times 2 \times \frac{22}{7} \times 14$  atau  $\frac{60}{360} \times 2 \times \frac{22}{7} \times 14$  atau  $\frac{90}{360} \times 2 \times \frac{22}{7} \times 14$  K1
- Lengkok AC + 14 + 14 + 19.80 atau  
Lengkok AB + lengkok BC + 14 + 14 + 19.80 K1  
84.47 N1
- (b)  $\frac{150}{360} \times \frac{22}{7} \times 14^2$  atau  $\frac{1}{2} \times 14 \times 14$  K1
- $\frac{150}{360} \times \frac{22}{7} \times 14^2 - \frac{1}{2} \times 14 \times 14$  atau K1
- $\frac{770}{3} - 98$
- $158\frac{2}{3}$  atau  $\frac{476}{3}$  atau 158.67 N1